



FULL INVERTER HEAT PUMPS

INVERTEMP-FL

Elegance in the
service of comfort



- Improved bathing comfort
- Optimal performance: the best technology
- Peace of mind: silence and reliability



INVERTEMP-FL

**Summer is the ideal season to enjoy your pool,
but why limit it?**

The Pentair InverTemp®-FL heat pump automatically heats or cools your pool according to the desired temperature. It adapts to outdoor conditions to ensure optimum bathing comfort while optimising consumption.

Equipped with Full Inverter technology, the new Pentair InverTemp®-FL heat pump delivers high and silent performances, thanks to the combination of an inverter compressor and a variable speed fan.

They adjust their speed automatically following the operating mode selected by the user via a smartphone or the WiFi TFT screen.



Control your
InverTemp-FL
thanks to

Smart Life



BENEFITS



High efficiency and optimised operation costs

The reversible InverTemp-FL heat pump is the most virtuous solution for heating or cooling your pool. Its performance coefficient is much higher than market standards. Precise temperature control prevents wasted energy.

Silence by the pool

InverTemp-FL is one of the quietest heat pumps on the market (<40 dB (A) @10 m in lab certified Boost mode).



Standalone operation

The heat pump automatically turns on/off to maintain the desired water temperature.



Eco-responsible and clean

The InverTemp-FL heat pump makes use of outside air and does not give off any smells or particles. No fuel storage space required. More environmentally friendly R32 refrigerant.



Remote monitoring

As well as its WiFi TFT screen, you can control this heat pump from your smartphone: very useful for programming the right temperature before your arrival. Compatible with the Speedeo®, Soleo® VS and Intellipool® automation systems, enabling control, diagnosis and alarm overview remotely (Interface modbus RS485).



Simple and intuitive interface.

Easy to use and control thanks to the WiFi TFT screen. Compatible with Pentair automation systems (Interface modbus RS485).



Independent defrosting

Its automatic active defrosting function prevents performance-damaging frost and enables it to operate at low temperatures (down to -15°C).



Built to last

Made with quality components that ensure a long service life (titanium exchanger).



More efficient R32 fluid with no impact on the ozone layer

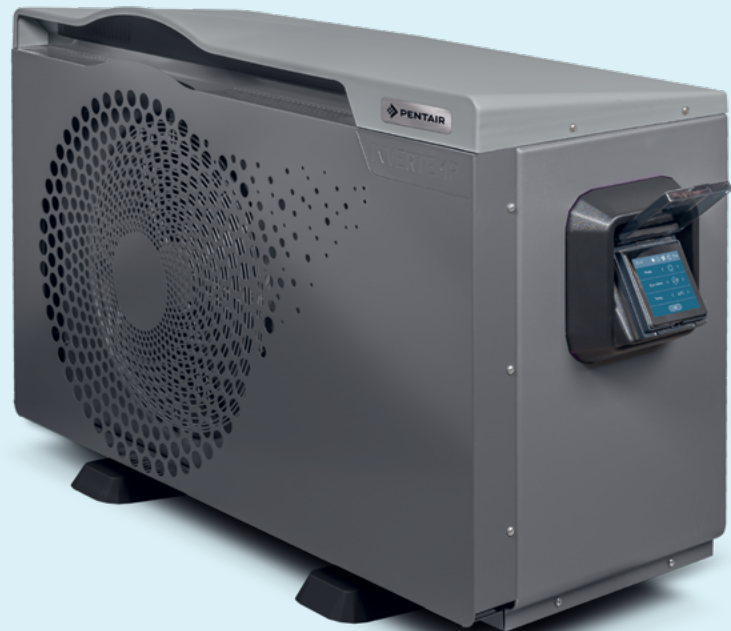

THREE OPERATING MODES

- + **Boost mode**
fast heating, ideal at the start of the season
- + **Eco-Silence mode**
silent operation, ideal during the season
- + **Smart mode**
optimum and automatic operation: maximum serenity

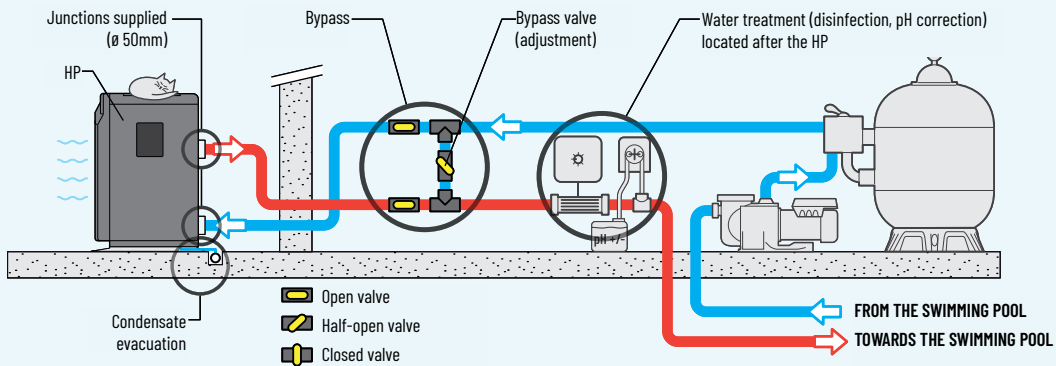

FIND THE MODEL FOR YOUR POOL!



⁽¹⁾ Recommended pool size (m ³)	Model	Heating power (Boost mode)				Sound pressure dB (A) @ 10m	Power supply
		Dry air 28°C - Relative humidity 80% Water temperature 28°C		Dry air 15°C - Relative humidity 70% Water temperature 26°C			
		kW	PC	kW	PC		
15-30	InverTemp-FL 1M	6.8	5.9 - 6.5	5.4	4.5 - 4.8	25 - 32	220-240V mono
30-45	InverTemp-FL 2M	8.8	5.5 - 6.5	6.6	4.4 - 4.9	25 - 33	
45-55	InverTemp-FL 3M	10.6	5.4 - 6.8	7.8	4.9 - 5.2	27 - 34	
55-70	InverTemp-FL 4M	12.8	5.6 - 6.8	9.8	4.5 - 5.0	28 - 39	
70-85	InverTemp-FL 5M	16.5	5.1 - 6.0	11.5	4.2 - 4.6	28 - 39	
85-105	InverTemp-FL 6M	20.1	5.2 - 5.9	14.6	4.3 - 4.6	29 - 40	
105-130	InverTemp-FL 7M	24.2	5.4 - 6.0	18.2	4.4 - 4.6	32 - 40	
130-160	InverTemp-FL 8T	27.8	5.2 - 5.9	22.8	4.2 - 4.5	31 - 42	

⁽¹⁾ For information purposes only for a private seasonal residential pool

⁽²⁾ According to the NF 414 standard



PENTAIR

PENTAIR POOL EUROPE

www.pentairpooleurope.com

All trademarks and logos shown are the property of Pentair.

Logos and trademarks of third parties are the property of their respective owners.

© 2021 Pentair, all rights reserved. invert-FL-FR_03/21_rev01



MORE VIRTUOUS POOLS WITH PENTAIR!

Learn more at:
blog.pentairpooleurope.com