



POOL PUMPS



VSF DISPLAY



5PXF™ VSF

VARIABLE SPEED PUMPS

Our high efficiency pumps for semi-commercial applications.

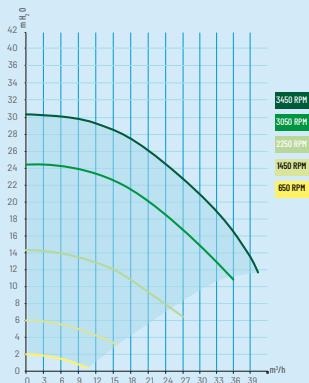

FEATURES

- ¼ turn opening lid
- XXXL pre filter basket
- Handle on the top
- Diamond seal
- Hydraulic isolator separating priming water from pumping water

BENEFITS

- Easy opening and locking
- Longer periods between cleanings
- Easier to carry
- Increased durability and tighter seal
- Faster priming, less turbulence and increased efficiency

TECHNICAL FEATURES

- 3hp permanent magnets motor, made in Italy, improved efficiency
- 8 programmable speed/time - simplified menus
- Rotatable LCD display / optional wall-mounting kit (PN. R356905)
- Real time clock with 24hrs retention
- TradeGrade exclusivity, only available on Whisper and XF lines.
- RS485 Modbus communication / Optional control cable (PN. R350122)
- Inlet/Outlet → 90 mm threaded
- Ø Unions → 75 mm or 90mm
- Unions included → Yes
- Salt resistancy → 0.40%

Part Number	Flow m³/h @ 8 m	Power output (kW)	(HP)	Volt (V)	Phase	Length (mm)	Weight (Kg)
5PXF-VSF	42	2.2	3	220-240	1~	740	28

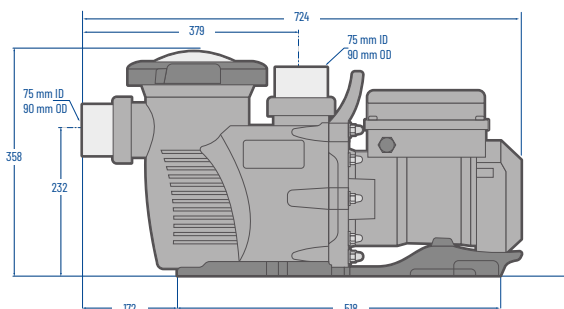

Packaging	Length (mm)	Width (mm)	Height (mm)	Pce/Palet
Box	74	37	37	-
Palet	120	80	150	9